

AC Input Tunable Color LED Modules with Casambi Dimming

CASAMBI

Input Voltage	Max. Source Lumens	Typ. Input Power	CCT Range	CRI	Dimming Method	Dimming Range
120 - 277 Vac	1500 lm 2300 lm	XX W	1800 - 6500 K	90+	Casambi	1-100%

Diameter: 50 mm (1.97 in)
Height: 19 mm (0.75 in)

Light Emitting Surface: 19 mm
Optical Source Size 14.8 mm

Light Emitting Surface: 12 mm
Optical Source Size 10 mm

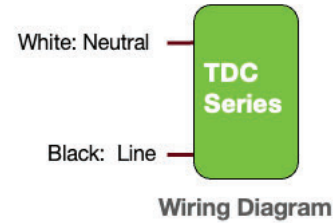
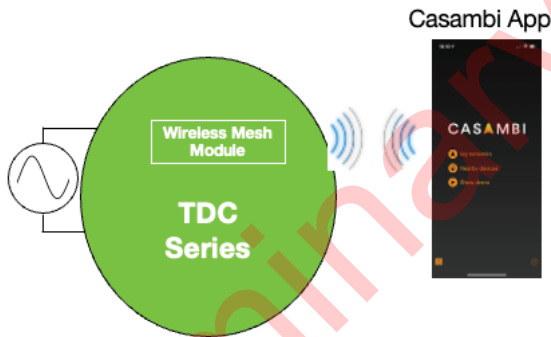
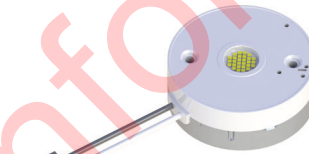
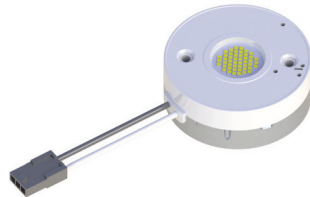

KEY FEATURES

- Casambi Wireless control
- Integrated AC to DC driver electronics
- Zhaga compliant footprint
- 3 modes of operation: Tunable white, Static White, Warm Dim
- Designed for field replaceability with front heat sink mounting
- Meets UL8750 Safety-Related Electronics Circuits (SREC) requirements
- Approved for use as thermal cutout for fixture per UL1598
- Configurable maximum light output
- Configurable tunable CCT range
- Warm dim ranges:
3050–1800 K (MR16 Halogen profile)
2700–1800 K (Incandescent profile)
- CA Title 24, IEEE 1789-2015, & Energy Star Compliant
- Compliant Color consistency of < 3 step (2 step typical) MacAdam ellipse
- On board overtemperature protection (OTP) with thermal foldback
- Circadian Rhythm lighting support with a controller



AC Input Tunable Color LED Modules with Casambi Dimming



1 - ORDERING INFORMATION

1.1 TDC - Base Part Numbers

Part Number	Light Emitting Surface (LES) (mm)	Maximum Input Power (W)	Typical Source Lumens (lm)	Typical Efficacy (lm/W) @ 4000 K	Notes
TDC-A5012W-13-9-CNS	12	XX	1300	95	Side Leads
TDC-A5019W-20-9-CNS	19	XX	2000	95	Side Leads

1.2 AC Input Power Cable (Ordered Separately)

Description	Part Number
2-wire AC Input Power Cable Assembly for Bianco, Black/White, 400 mm (15,7 in), for North America	AC-BIA-NA
2-wire AC Input Power Cable Assembly for Bianco, Black/White, 610 mm (24 in), for North America	AC-BIA-NA-610
2-wire AC Input Power Cable Assembly for Bianco, Black/White, 100 mm (3.94 in), for North America	AC-BIA-NA-100
2-wire AC Input Power Cable Assembly for Bianco, Black/White, 413 mm (15.7 in), with quick disconnect, for North America	AC-BIA-NAQD
2-wire AC Input Power Cable Assembly, Black/White, 400 mm (15.7 in), with quick disconnect and flying leads, for North America	AC-NAQD-FL

AC Input Tunable Color LED Modules with Casambi Dimming

CASAMBI

1 - ORDERING INFORMATION

1.3 TDC - Secondary Optic Compatibility (Ordered Separately)

Part Number	Lens Adapter		
	LADA-BIA50-19-TIRA	LADA-BIA50-12-TIRA	LADA-BIA50-09-TIRA
Description	Optics adapter for LEDR, 19 mm aperture	Optics adapter for LEDR, 12 mm aperture	Optics adapter for LEDR, 9 mm aperture
TDC-A5019W	√	X	X
TDC-A5012W	√	√	X

Part Number	Lens	
	LEDR-BIA50-MN5024-50	LEDR-BIA50-MN5024-24
Description	50 mm outer diameter, 24 mm aperture TIR lens, 50° beam angle	50 mm outer diameter, 24 mm aperture TIR lens, 24° beam angle
TDC-A5019W	√	X
TDC-A5012W	X	√

1.4 Programming Tools (Ordered Separately)

Description	Part Number
Programming Cradle for 50 mm Diameter Casambi Light Engines, Requires PROG-JACK-USB for Connecting to Computer	PROG-CAS50-CRADLE
Programming Cable, USB to 3.5 mm Audio Jack	PROG-JACK-USB

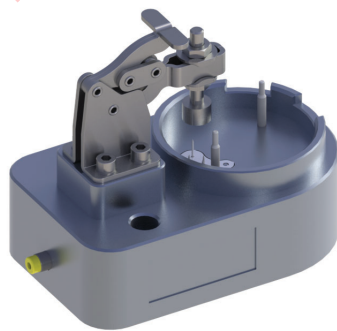

PROG-CAS50-CRADLE



PROG-JACK-USB

AC Input Tunable Color LED Modules with Casambi Dimming



2 - OPERATIONAL SPECIFICATIONS

2.1 Electrical Specifications (@ 25 °C Ambient Temperature)

Specification	Units	Minimum	Typical	Maximum	Notes
Input Voltage Range	Vac	90	120, 277	305	
Input Frequency Range	Hz	47	50/60	63	
Input Current	mA	-	-	XX mA @ 120 Vac XX mA @ 277 Vac	
Power Factor		0.9	> 0.9		At nominal input voltage and 100% output
Total Harmonic Distortion (THD)	%	-	-	20 %	At nominal input voltage, and from 100% to 40% of rated lumen output
Inrush Current	A	Meets NEMA-410 requirements			At any point on the sine wave and 25 °C
Leakage Current	mA	-	-	0.32 mA @ 120 Vac 0.75 mA @ 277 Vac	Measured per IEC60950-1
Input Harmonics	Complies with IEC 61000-3-2 for Class C equipment				
Standby Power	mW	-	-	XX mW @ 120 Vac XX mW @ 277 Vac	
Start Time	ms	-	≤ 300	500	

AC Input Tunable Color LED Modules with Casambi Dimming



2 - OPERATIONAL SPECIFICATIONS

2.2 Photometric Specifications (@ 60 °C Substrate Temperature, T_s)

Specification	Range	Notes
Lumens	≤ 1300, 2000 lm	Listed light output and efficacy refers to light output from the source. Diffuser lenses and additional optics will affect final light output and efficacy. See page 6 for characterization charts.
Efficacy (LPW)	95 lm/W	
CCT (Tunable Range)	1800–6500K	-
CCT (Warm Dim Range)	3050–1800 K (MR16 Halogen profile)	Warm Dim profile selectable via Casambi app.
	2700–1800 K (Incandescent profile)	
CRI (Ra)	90+	2700–6000 K
CRI (R9)	50+	2700–6000 K
Nominal Color Consistency (Duv)	± 0.0033	< 3 step MacAdam ellipse (SDCM) at 100% output (2 step typical).
Lumen Maintenance	L70 (70% of initial lumens) at 50,000 hours at T _c ≤ 75°C.	
Flicker	Compliant with IEEE 1789-2015.	

AC Input Tunable Color LED Modules with Casambi Dimming



2 - OPERATIONAL SPECIFICATIONS

2.3 Lumen and Color Performance Data (PLACEHOLDER)

Typ. Lumen Output at Various CCT Points

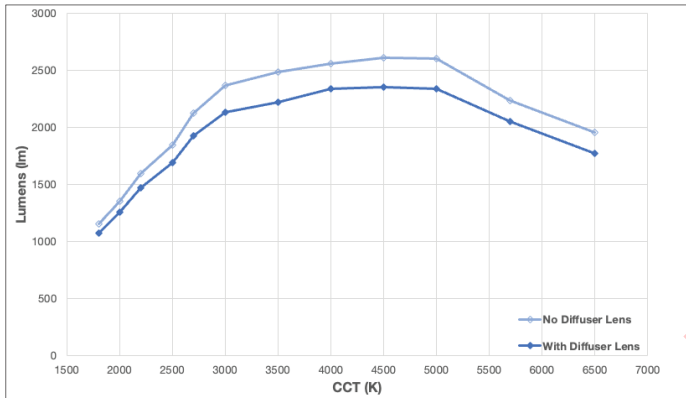

Typ. Efficacy (LPW) at Various CCT Points

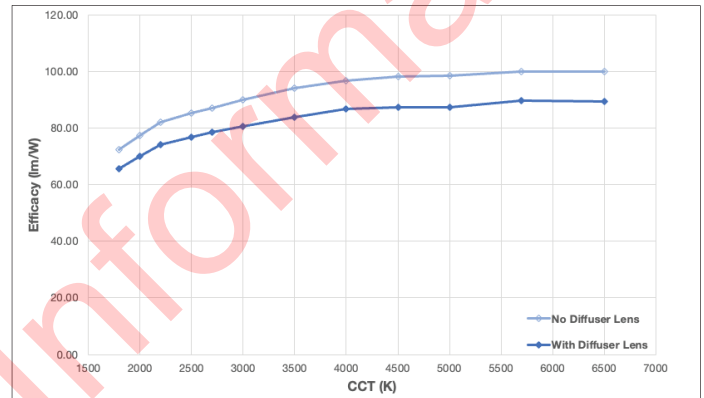

Spectral Power Data (SPD) at Various CCT Settings

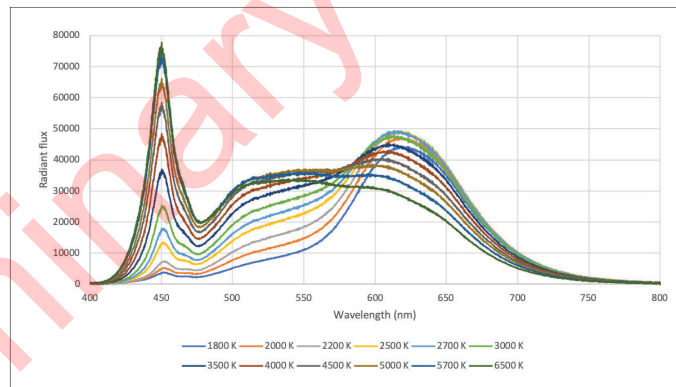

CRI (Ra and R9) at Various CCT Points

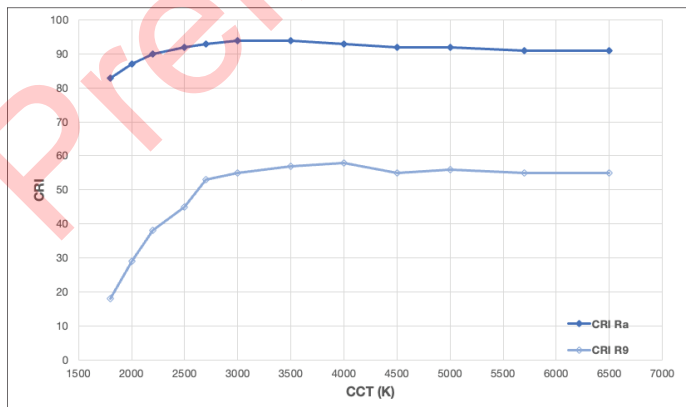

12 Selectable CCT Points in the CIE 1931 Color Space

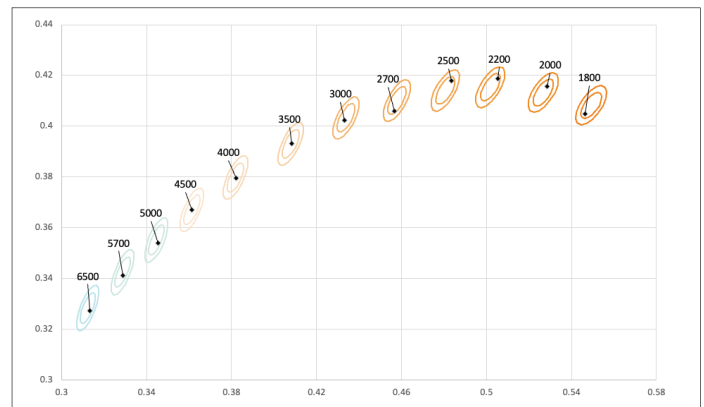

AC Input Tunable Color LED Modules with Casambi Dimming



2 - OPERATIONAL SPECIFICATIONS

2.4 Environmental and Safety Specifications

Specification	Units	Minimum	Maximum	Notes
Operating Ambient Temperature (Ta)	°C	-20	40	
Maximum Case Temperature (Tc)	°C	-	90	
Storage Temperature	°C	-40	85	
Humidity	%	5	95	Non-condensing.
Acoustic Noise	dBA	-	24	Measured at a distance of 1 foot (30 cm)

Specification	Notes
Mechanical Shock Protection	As per EN60068-2-27.
Vibration Protection	As per EN60068-2-6 & EN60068-2-64.
MTBF	> 200,000 hours when operated at nominal input conditions, and at $T_c < 75^\circ\text{C}$.
Driver Lifetime	50,000 hours at $T_c = 75^\circ\text{C}$ maximum case hot spot temperature.
Conducted & Radiated EMI	Compliant with FCC CFR Title 47 Part 15 Class B at 120 Vac, Class A at 277 Vac.

Specification	Type	Standard	Notes
Harmonic Current Emissions	-	IEC 61000-3-2	For Class C equipment.
Immunity Compliance	ESD (Electrostatic Discharge)	IEC 61000-4-2	6 kV contact discharge, 8 kV air discharge, level 3.
	Electrical Fast Transient	IEC 61000-4-4	2 kV on AC power port for 1 minute, 1 kV on signal/control lines.
	Surge	IEC 61000-4-5	2 kV line to line (differential mode) / 2 kV line to common mode ground.
		ANSI/IEEE c62.41.1-2002 & c62.41.2-2002 category A, 2.5 kV ring wave.	
High Pot or Dielectric Voltage Withstand		2200 Vdc	Tested between 0–10 V leads and AC input.

Safety Agency	Notes
UL	UL recognized component. Safety-Rated Electronic Circuit (SREC) rated
NEMA	SSL-1-2016
CA Title 24	Compliant
ENERGY STAR®	Compliant

AC Input Tunable Color LED Modules with Casambi Dimming

CASAMBI

3 - MECHANICAL SPECIFICATIONS

Specification	Notes	
Dimensions	Diameter:	50 mm (nominal 1.97 in)
	Height:	19 mm (nominal 0.71 in)
Light Emitting Surface (LES)	19 mm, 12 mm	
TDC Weight	71 g (2.5 oz)	
Heat Sink Attachment	Front-mount, countersunk, M3 x 0.5 x 25 mm Recommended torque: 0.59-0.79 N*m (5.2-6.9 lb*in)	

Note: See next section for details on the cable assemblies for TDC.

AC INPUT

WIRE-TO-WIRE CONNECTOR, MICRO-FIT
PLUG HOUSING, 3.0 PITCH, 3 CIRCUITS (1-VOID)
MPN: MOLEX 436400301 / LHE MX3.0-1X3AF
WIRE, 18AWG, 300V, 105°C RATED, STRANDED

N: (1) WHITE
L: (2) BLACK

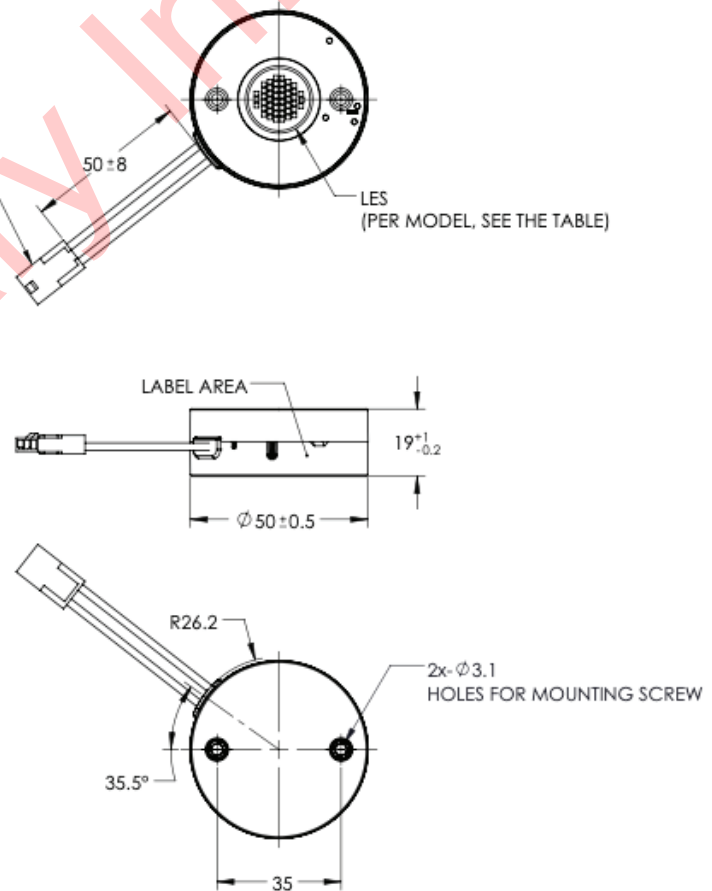

Note: All dimensions are in millimeters.

AC Input Tunable Color LED Modules with Casambi Dimming



4 - CABLE ASSEMBLIES

4.1 2-Wire AC Input Power Cable Assemblies for TDC

General Specifications for Power Cable Assemblies

Item No.	Part No.	Manufacturer	Description	Quantity
1	3016H-1*03	ECI	Connector 3-Pin	1
2	3016P-L	ECI	Connector Crimp	2

For North America

Part Number: AC-BIA-NA

Length: 400 mm (nominal 16 in.)

Item No.	Part No.	Wire Description	Wire Color	Input	Qty.
3	UL 1430	Wire Stranded Tinned 18 AWG (Pin-1)	White	Neutral	1
4	UL 1430	Wire Stranded Tinned 18 AWG (Pin-3)	Black	Line	1

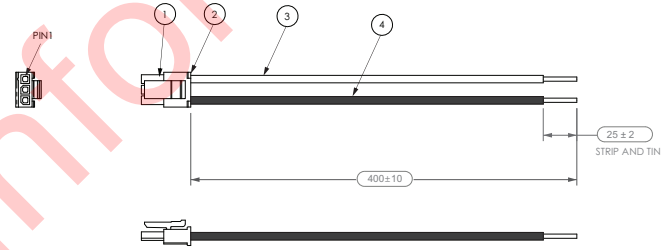

For North America, with Quick Disconnect

Part Number: AC-BIA-NAQD

Length: 413 mm (nominal 16.25 in.)

Item No.	Part No.	Description	Color	Input	Qty.
3	UL 1430	Wire Stranded Tinned 18 AWG (Pin-1)	White	Neutral	1
4	UL 1430	Wire Stranded Tinned 18 AWG (Pin-3)	Black	Line	1
5	SA2-10, SINGLE	NBC ELECTRONIC 2-Pin Connector	Orange	N/A	1

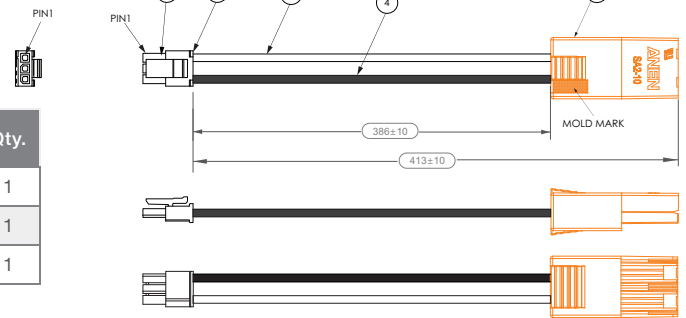

For North America, with Quick Disconnect

Part Number: AC-NAQD-FL

Length: 413 mm (nominal 16.25 in.)

Item No.	Part No.	Description	Color	Input	Qty.
1	UL 1430	Wire Stranded Tinned 18 AWG (Pin-1)	White	Neutral	1
2	UL 1430	Wire Stranded Tinned 18 AWG (Pin-3)	Black	Line	1
3	SA2-10	NBC ELECTRONIC 2-Pin Connector	Orange	N/A	2

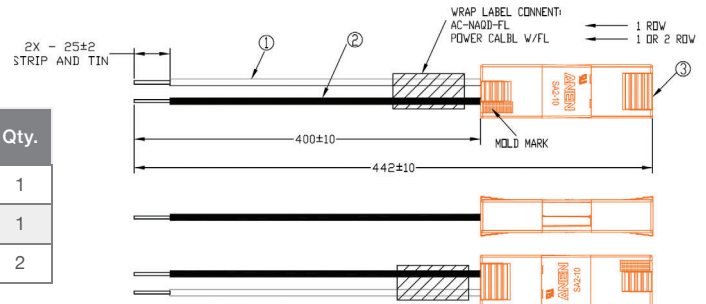

Note: All dimensions are in millimeters.

AC Input Tunable Color LED Modules with Casambi Dimming

CASAMBI

5 - HEAT SINKING RECOMMENDATIONS

In most applications, a heat sink that would be used to cool the COB the TDC replaces will be sufficient to cool the engine. However, with color products, the LPW is significantly lower than static white products. For example, a heatsink being used to cool a white COB with an LPW of 150+ will not sufficiently cool a color product at the same lumens. Color applications tend to achieve an efficacy of 80-100 LPW.

The TDC is tested on standard heatsinks with known thermal resistance, using three sizes shown below. These heatsinks offer a starting point as to how large a heatsink needs to be to support a given Lumen output.

To verify this, once mounted to the planned heatsink, thermocouple the Tc point on the base of the engine. A target temperature of less than Tc 70C at the max ambient temperature for the application indicates sufficient heat sinking.

If the measured temperature is above this, the heatsink will need to be changed. The TDC will fold back lumens if the LED array temperature exceeds 85C which will happen at approximately 70C Tc.

A thermal conductive material of greater than 8W/m*K is recommended for mounting the engine to the heatsink.

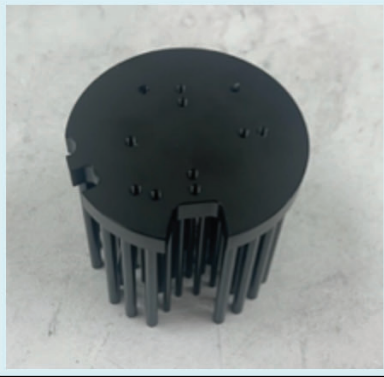
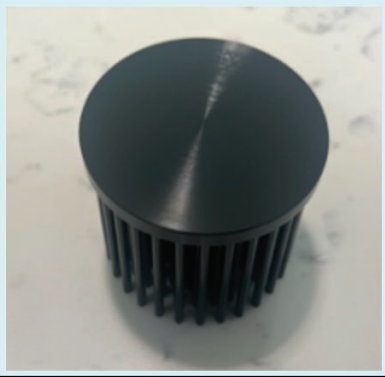
Manufacturer Model	Mechatronix GH36D 9980-B	Mechatronix LPF67A68-8-B	Mechatronix LPF70A50-5-B
			
	GH36D 9980-B, 120 Vac, Rev. X04, 4000K CCT	LPF67A68-8-B, 120 Vac, Rev. X04, 4000K CCT	LPF70A50-5-B, 120 Vac, Rev. X04, 4000K CCT
Light Engine Output (Lumen)	Ts at Ta of 40 °C		Ts at Ta of 40 °C
850			
1000			69.1
1250			74.5
1500		72.8	79.9
2000		82.5	91.5
2500 (Max)	64.9	85.3	97.4

AC Input Tunable Color LED Modules with Casambi Dimming

CASAMBI

6 - TEMPERATURE MEASUREMENT POINTS

The thermal management characteristics of the heat sink used with the TDC should be validated by measuring its **case temperature (T_c)**. This test should be done with the TDC installed in the fixture at ambient temperature and air flow conditions similar to the end-use installation. It is recommended that the thermal management system be designed for a $T_c < 75\text{ }^\circ\text{C}$.

TDC has on-board over temperature protection (OTP) which will throttle the currents to the LED arrays. The CCT at which the unit is operating will be maintained in this mode, but the output lumens will drop. This ensures that the LEDs are not subjected to abnormal temperatures.

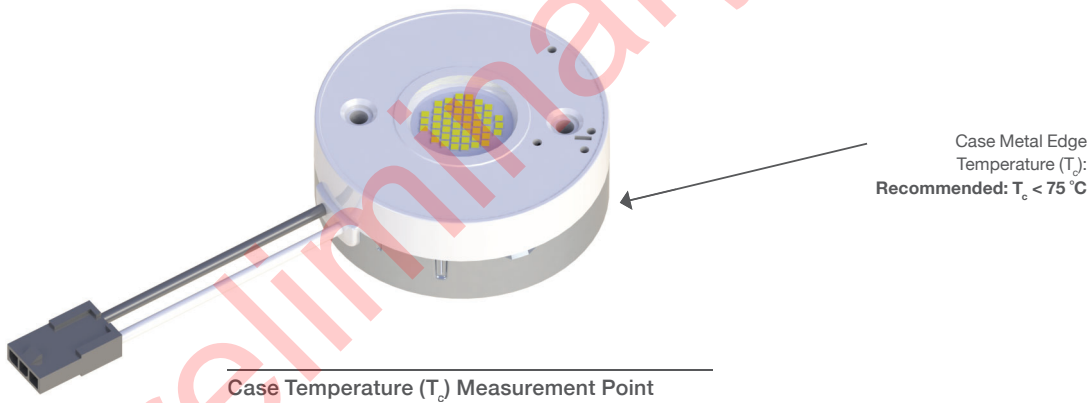

Note: All dimensions are in millimeters.

AC Input Tunable Color LED Modules with Casambi Dimming

CASAMBI

■ 7 - LABELING

The XX is used as an example to illustrate a typical label.

USA Headquarters

Tel: +1-805-517-1300
Fax: +1-805-517-1411
2625 Townsgate Rd, Suite 106
Westlake Village, CA 91361z, USA

CHINA Operations

Tel: +86-756-6266298
Fax: +86-756-6266299
No. 8 Pingdong Road 2
Zhuhai, Guangdong, China 519060

ERP Power, LLC (ERP) reserves the right to make changes without further notice to any products herein. ERP makes no warranty, representation or guarantee regarding the suitability of its products for any particular purpose, nor does ERP assume any liability arising out of the application or use of any product or circuit, and specifically disclaims any and all liability, including without limitation special, consequential or incidental damages. "Typical" parameters which may be provided in ERP data sheets and/or specifications can and do vary in different applications and actual performance may vary over time. All operating parameters, including "Typicals" must be validated for each customer application by customer's technical experts. ERP does not convey any license under its patent rights nor the rights of others. ERP products are not designed, intended, or authorized for use as components in systems intended for surgical implant into the body, or other applications intended to support or sustain life, or for any other application in which the failure of the ERP product could create a situation where personal injury or death may occur. Should Buyer purchase or use ERP products for any such unintended or unauthorized application, Buyer shall indemnify and hold ERP and its officers, employees, subsidiaries, affiliates, and distributors harmless against all claims, costs, damages, and expenses, and reasonable attorney fees arising out of, directly or indirectly, any claim of personal injury or death associated with such unintended or unauthorized use, even if such claim alleges that ERP was negligent regarding the design or manufacture of the part. ERP is an Equal Opportunity/Affirmative Action Employer. This literature is subject to all applicable copyright laws and is not for resale in any manner.